

No. XREFS
I: \\Key_Std\SAS\Details\dwg\Sasd-PUB-4s.dwg

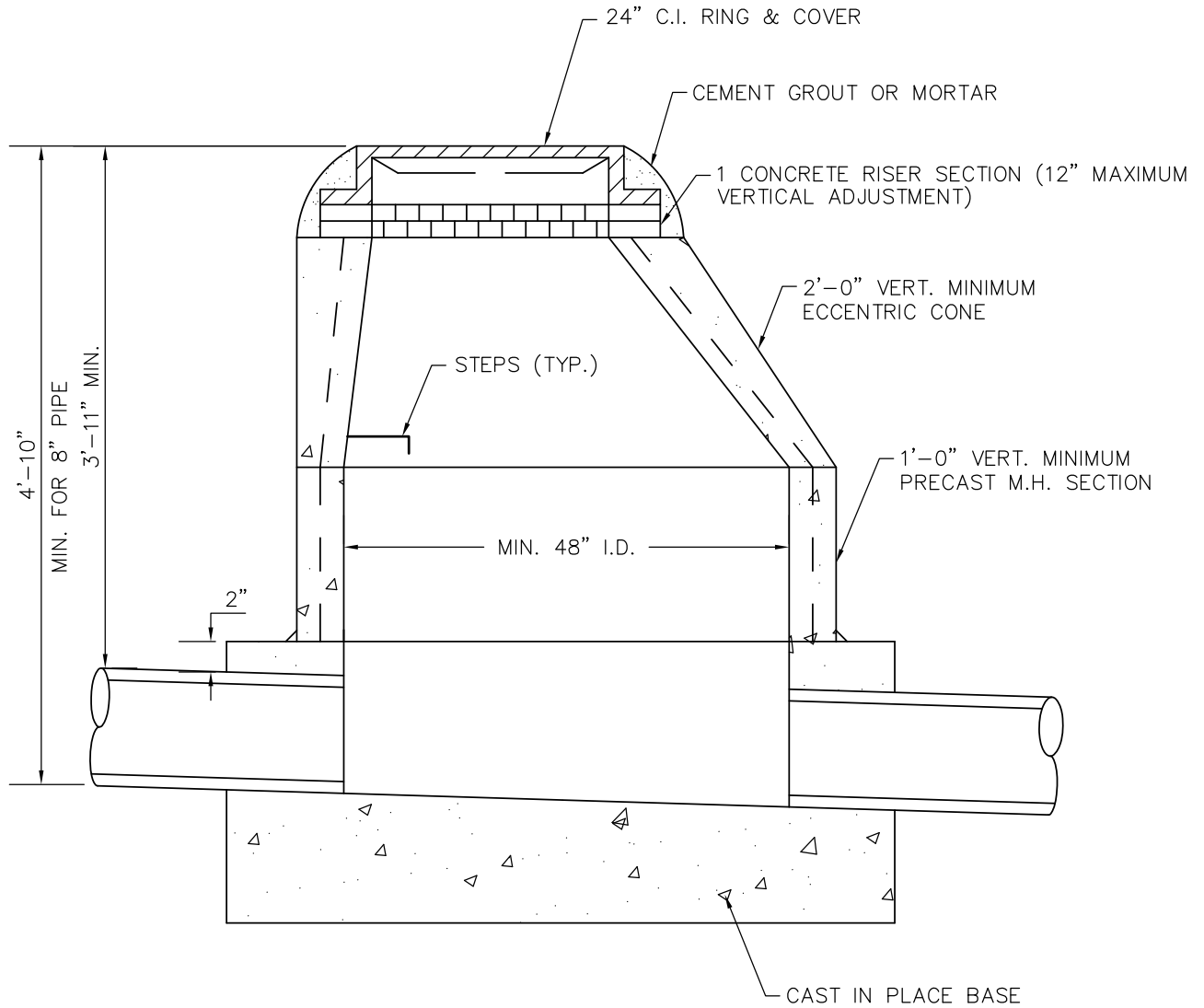

NOTE:

1. USE THIS DETAIL IN CONJUNCTION WITH THE "PRECAST MANHOLE DETAIL."
2. FOR USE WITH MANHOLES WITH LESS THAN 6 FEET OF COVER.
3. USE OF MINIMUM DEPTH MANHOLES REQUIRES PRIOR WRITTEN APPROVAL FROM THE DISTRICT AND/OR THE DISTRICT ENGINEER.

Kennedy/Jenks Consultants

Engineers & Scientists

143 Union Boulevard
Suite 600
Lakewood, CO 80228
303 985 3636 TEL.
303 985 3800 FAX



SOUTH ARAPAHOE
SANITATION DISTRICT

www.southarapahoe.org

**MINIMUM DEPTH
MANHOLE DETAIL**

DRAWING NO.: SASD-PUB-4S DATE: 10/11