

COPOLYMER POLYPROPYLENE PLASTIC

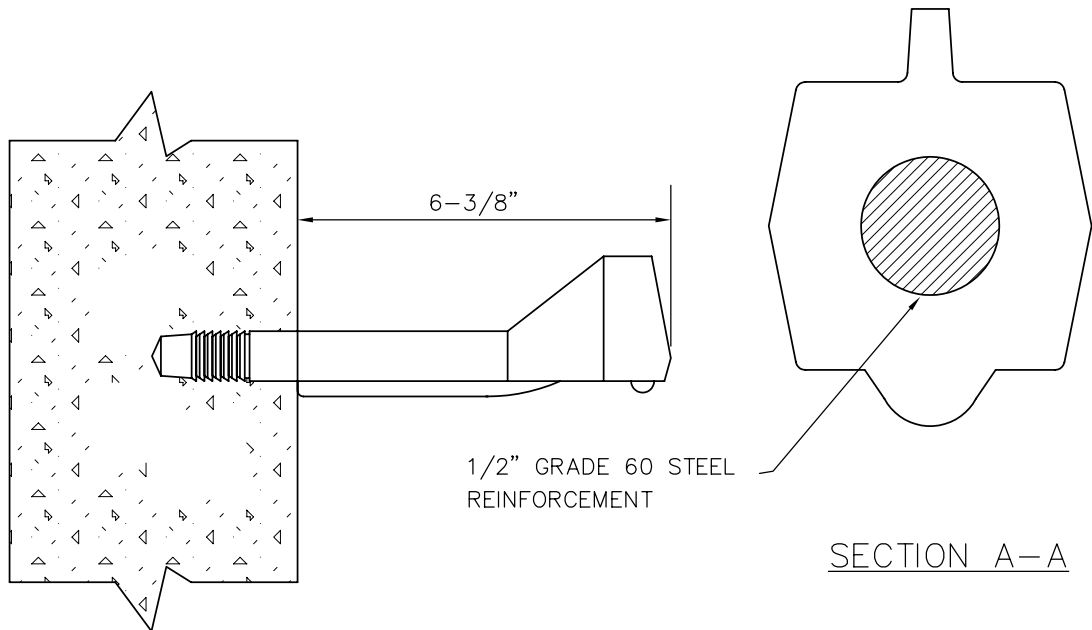

SECTION A-A

No. XREFs  
 I: \\Key\_Std\SAS\Details\dwg\Sasd-PUB-7s.dwg

**Kennedy/Jenks Consultants**  
 Engineers & Scientists

143 Union Boulevard  
 Suite 600  
 Lakewood, CO 80228  
 303 985 3636 TEL  
 303 985 3600 FAX



**SOUTH ARAPAHOE**  
 SANITATION DISTRICT  
 www.southarapahoe.org

**PLASTIC  
 STEP DETAIL**

DRAWING NO.: SASD-PUB-7S DATE: 5/08